

# Mathématiques SANS Frontières

# 2020

UNIVERSITY OF THE  
WEST of SCOTLAND  
**UWS**

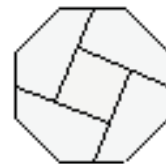

The Scottish Mathematical Council

Even partial solutions and attempts can get marks.

Neat and careful work is important.

Hand in only one team answer sheet for question

## Q.1 (7 points) Who's next?

Give your answers in French, German, Spanish or Italian using a minimum of 30 words.

La signora e il signor Propre abitano con i loro quattro figli in un grande appartamento con due bagni.

Sono soliti fare colazione in famiglia e ciò complica l'uso dei bagni. La signora Propre occupa un bagno 21 minuti e il marito 15 minuti. I figli Justine, Samuel, Tristan e Nora li occupano rispettivamente 14, 8, 13 e 7 minuti.

La famiglia Propre prevede 20 minuti per la colazione. Tutti escono alle otto del mattino.

**Poiché la famiglia desidera organizzarsi in modo che tutti possano dormire il più a lungo possibile, a quale ora i primi due devono accedere ai bagni? Illustrate la loro organizzazione.**

Monsieur et Madame Propre habitent avec leurs quatre enfants dans une grande maison disposant de deux salles de bain. Ils aiment prendre leur petit-déjeuner en famille, ce qui rend l'occupation des salles de bain très compliquée. Madame Propre occupe la salle de bain 21 min et Monsieur Propre 15 min. Les enfants Justine, Samuel, Tristan et Nora l'occupent respectivement 14 min, 8 min, 13 min et 7 min.

La famille Propre prend le petit-déjeuner, ensemble, en 20 min. Tous quittent la maison à huit heures.

**Sachant que la famille souhaite dormir le plus longtemps possible, à quelle heure la première personne doit-elle aller dans une salle de bain ?**

**Donner une organisation possible.**



El señor y la señora Propre viven con sus cuatro hijos en una casa grande con dos cuartos de baño. Les gusta desayunar en familia, lo que complica mucho la utilización de los cuartos de baño. La señora Propre ocupa el cuarto de baño 21 min y el señor Propre 15 min. Los hijos Justine, Samuel, Tristan y Nora lo ocupan 14 min, 8 min, 13 min y 7 min, respectivamente.

La familia Propre desayuna, junta, en 20 min. Todos dejan la casa a las ocho de la mañana.

**Sabiendo que la familia desea dormir el mayor tiempo posible, ¿a qué hora debe ir la primera persona a un baño? Dar una posible organización.**

Die Familie Propper besteht aus 6 Personen – aus Herrn und Frau Propper und ihren 4 Kindern. Die Familie liebt es, morgens zusammen zu frühstücken. Vor dem Frühstück möchte natürlich jedes Familienmitglied ins Bad gehen. Im Haus der Familie Propper gibt es zwei Badezimmer. Frau Propper braucht morgens 21 Minuten im Bad, Herr Propper 15 Minuten. Die Kinder Justine, Samuel, Tristan und Nora brauchen 14, 8, 13 und 7 Minuten.

Um 8 Uhr müssen alle aus dem Haus gehen. Das gemeinsame Frühstück dauert 20 Minuten.

**Wann muss das erste Familienmitglied ins Bad gehen, wenn alle so lange wie möglich schlafen wollen? Wie kann die Familie die**

**Benutzung der Bäder am besten organisieren? Gebt eine Möglichkeit an**



---

## Q.2 (5 points) Hexa-ordinary.

---

Construct three regular hexagons with sides of 4cm. Cut the first hexagon as shown. Also cut the second hexagon into six equilateral triangles and, the third hexagon into six isosceles triangles as shown in the figure.

**With these 13 shapes, create a large regular hexagon and stick it to your answer sheet.**

**Calculate the length of the side of the large hexagon. Explain your answer.**

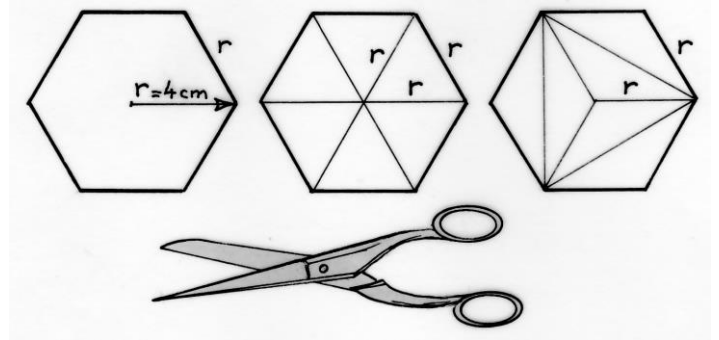

---

### Q.3 (7 points) Mentalist

---

Elyne is a mentalist – she pretends to read the thoughts of others. She hands a calculator to Thomas and asks him to:



- Choose a three-digit number and don't tell me what it is
- Multiply your number by 21
- Multiply the result, as you choose, by 3 or 4 or 5 or 6
- Divide this result by 4 and then by the original number you chose
- Add your original number to this result
- Read back to me the final number shown on the calculator.

Elyne, while looking at Thomas, tells him what his original number was.

**Explain how Elyne was able to know the original number.**



---

### Q.4 (5 points) Run ahead

---

Eloi and Martin run a 100-metre race. During the first race, Eloi wins with a 5m lead. In order to make the rematch fairer, Eloi begins the race 5m behind the start line. Eloi and Martin both run at the same speed as in the first race.

**Who will win the second race? Explain.**



---

### Q.5 (7 points) Many-fold

---

Antoine constructs a tetrahedron using the dimensions shown in the picture. He wishes to calculate the volume of the tetrahedron but is not sure how to achieve this. The only useful information he can find on the internet is following formula:

$$\text{Volume of tetrahedron} = \frac{\text{Area of base} * \text{height}}{3}$$

**Construct the net of this tetrahedron and attach it to your answer sheet.**

**Calculate the volume of the tetrahedron rounded to the nearest whole number.**

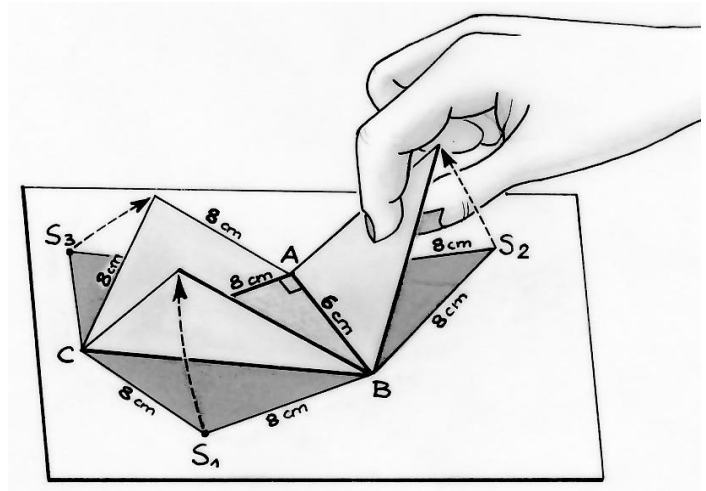

---

### Q.6 (5 points) Garden squares

---

The shared garden of Viereckheim has an island in the heart of “All Squares” section where fruits and vegetables are grown. The garden was created using nine squares used for growing different crops, as shown in the picture. Square A has an area of 81 square metres and B has an area of 64 square metres.

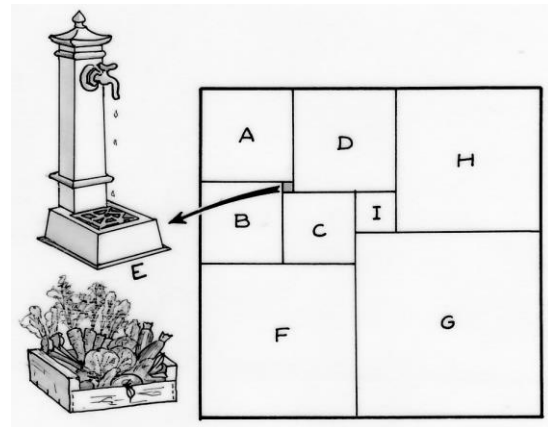

**Is the garden formed by combining these nine square areas also a square?  
Justify your answer.**



---

### Q.7 (7 points) And yet it turns!

---

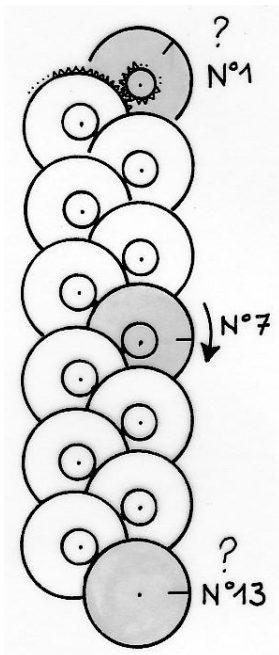

The clock shown is found in the Dynamikum Science museum in Pirmasens, Germany. It is made up of thirteen identical large cogwheels. Each large cogwheel contains a pinion with the same axis. A pinion has exactly seven times fewer teeth than the large cogwheel. Each pinion drives the large cogwheel beneath it.

Hence, each large cogwheel makes seven times fewer turns than the pinion that drives it.

Wheel #1 drives all the others. Wheel #7 makes exactly one revolution in 24 hours.

**Determine the direction of rotation for Wheel #1, and give an approximate value of the number of revolutions per second for this wheel. Explain your answer.**

**Determine the direction of rotation for Wheel #13, and the number of years required to make one revolution. Explain your answer.**





---

### Q.8 (5 points) Decipher the letters

---

Each letter in the multiplication table represents a different digit.

Reproduce the multiplication table, replacing each letter by its corresponding digit.

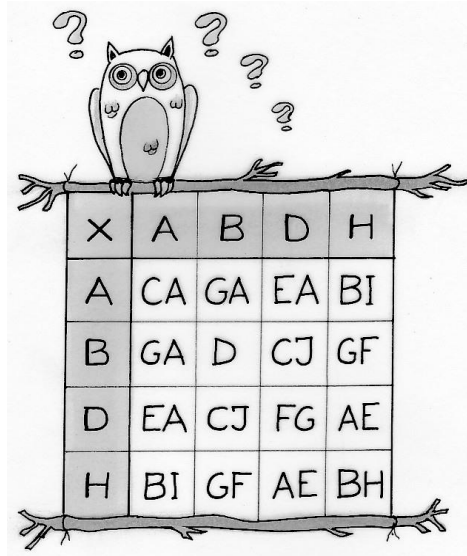

X	A	B	D	H
A	CA	GA	EA	BI
B	GA	D	CJ	GF
D	EA	CJ	FG	AE
H	BI	GF	AE	BH



## Q.9 Multiplication without boundaries (7 points)

Multiplication "*per gelosia*" was widely used in the 14th and 15th centuries. The name "*per gelosia*" comes from "à jalousies" shutters through which light passes diagonally and that allow you to see without being seen. Nowadays, in India, a fairly similar technique is used.

The drawings represent multiplication of 67 by 82 using these two techniques.

**Set up, and carry out, the multiplication of 37 by 546 using these two techniques.**

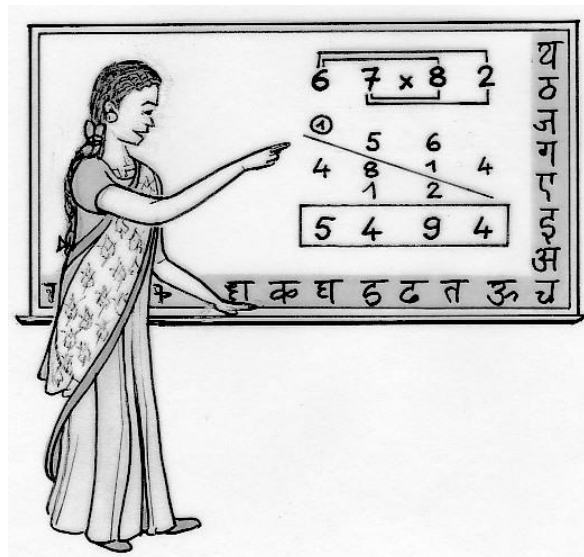
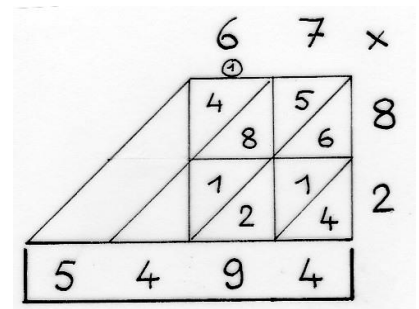

## Q.10 All in good time (10 points)

A timer is made up of three polygons: a triangle, a square and a pentagon. In each polygon, a needle points towards one of its vertices. In the initial position in figure (0), the three needles are superimposed.

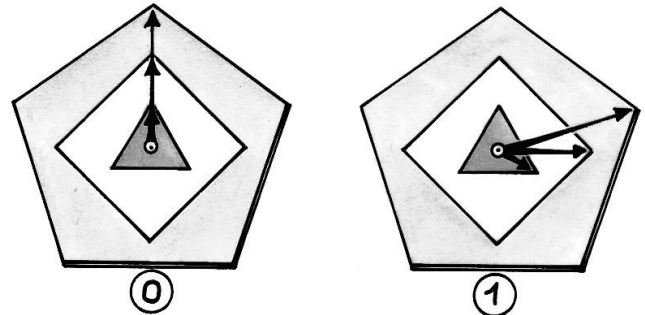

Each minute, each needle turns clockwise to the next vertex; this is shown in figure (1).

**From the initial position, determine the number of minutes that have elapsed when the needles are positioned for the first time as in figure A.**

**Position the three needles on figure B so that this corresponds to 51 minutes passed.**

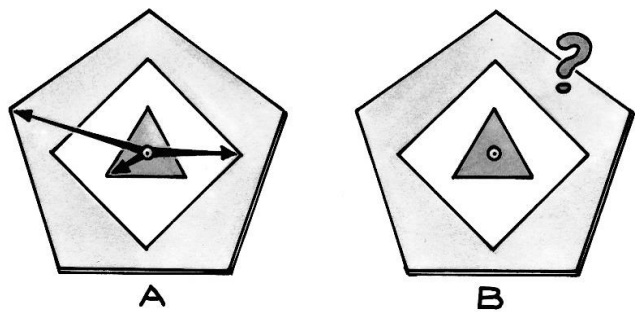

**Which polygons should be chosen to make a three polygon timer that returns to its initial position in 105 minutes?**



# SENIOR CLASSES ONLY

## Q.11 “Ay Caramba” (5 points)

Each of three robots draw a “line path” on a rectangular grid. Their paths are shown on the grid by solid lines. Pretty has covered 185mm and Jerry 145mm.

With the aid of a sketch, determine the length of Speedy’s path. Justify your answer.

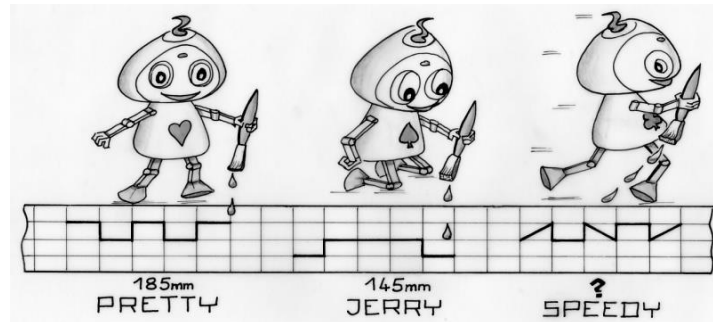

---

### Q.12 Corollary? (7 points)

---

Romain and Émilie obtained two different figures using the same construction programme, as follows.

- Draw a segment  $AB$  of length 4cm.
- Draw a circle with centre  $O$  passing through  $A$  and  $B$ .
- Position the midpoint,  $M$ , of  $AB$ .
- Draw the circle with radius  $OM$ .
- Shade the area of the circular crown obtained.

**Draw two different figures using this construction programme. Compare the shaded areas. Justify your answer.**

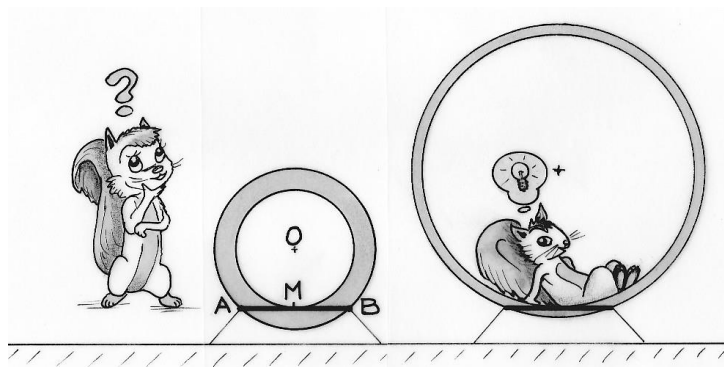

---

### Q.13 Play Back? (10 points)

---

Jean and Pierre wish to cause water to overflow from a rectangular trough which is 60cm long, 40cm wide and 30cm high.

They take it in turns to place identical cubes of side 20cm in the trough. The cubes are heavy enough to be placed at the bottom of the trough, stored flat and side-by-side.

Having placed the first cube, Jean spots that the water has risen 3cm, but the cube is not totally submerged.

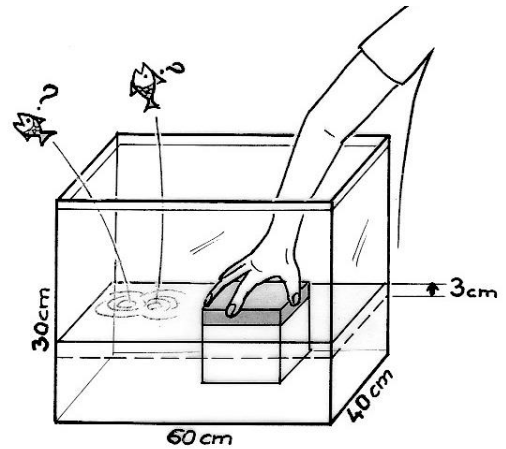

**Determine which of the two boys will place a cube in order that the water in the trough overflows. Justify your answer.**

